

Contents

1. Machine property and safety information.....1~2
2. Machine specification, installation and debug.....3~6
3. Principle of operation and flow.....6~8
4. Machine operation.....8~12
5. Maintenance and troubleshooting.....12~16
6. Main parts and components illustration and parts list.....17~32
7. Electric Illustrative Diagram and Subassembly list.....33~41

1. Machine Property and safety information

Company name and address

Company Name: Hangzhou Youngsun Machinery Co., Ltd.

Company Address: Kangxin Building C Stand,12F, No. 569,Wensan Road ,Hangzhou

Manufacturer Address: No.1, Western Garden, 9th Road, the West Lake Science and Technology Zone, Hangzhou

Performance parameter

Item	Specification
	MH-102A
Power supply and Power	380V/50Hz, 1000W/5A
Bailing speed	≤2.5second/ path
Strapping force	0-60kg
Requirement for bailing strap	Width 13mm, thickness 0.83mm
Strapping mode	Parallel strapping, 1~several strips, modes: photoelectric control, manual operation, etc.
Dimensions	L1580×W650×H1418mm
Frame size	Width 800mm*Height 600mm(It's possible to customize according to your requirements.), equivalent to inside width 934mm*inside height 600mm
Packing measurements	L1740×W800×H1140mm (2m ³)
Weight	280kg
Noise	≤75DB
Environment condition	Humidity≤98%, temperature 0-40℃
Bottom adhesion	Adhesive surface≥90%, adhesive width≥20%, deviation of adhesive position≤2mm
Remark	Adhesive position is 615mm from the ground

Machine nameplate

Mei Wa [®] Youngsun [®]	打包机 Strapping machine	
型号:MH-102A Model	电源: AC380V 50Hz 1KW Power	
打包速度:2.5秒/道(s/each binding) Binding speed	重量:280kg N. W.	
规格:800x600 Specification	出厂日期: Delivery date	
杭州永创·美华打包机械有限公司制造 HANGZHOU YOUNGSUN · MEIWA PACKING MACHINERY CO., LTD 地址: 中国·浙江省杭州市文三路569号康新大厦C座12层 ADDRESS: Kangxin Building C stand, 12F, Wensan RD NO. 569, Hangzhou, Zhejiang Province, China 邮编: 310012 P. C 联系电话: (86)571-85120100 (85120101、85120102、85120103) TEL 传真: (86)571-87979569 FAX E-mail: info@youngsunpack.com Made in China		

Outline and application field

This machine adopts PLC control and its electric subassembly is world famous products such as Japan “OMRON”, Taiwan “MCN”, French “TE” electrics. Machinery design adopts Japan technology. Reasonable design, harmonious action, high reliability. Three functions: manual, automatic, continual. Convenient use, rapid speed. Suitable for high-speed production water line operation. Aluminum alloy rack. Free from charging oil maintenance.

This machine is with a wide range application, applied to chemical fiber field, tobacco leaf redrying, pharmacy, publication, refrigeration and air-conditioner, household appliances, ceramics, hot work, etc.

Stand position of operation (refer to Fig 1-1)

While operation, the operating staff stands right ahead the machine 10cm from the machine (freely operating the case sealing object is appropriate).

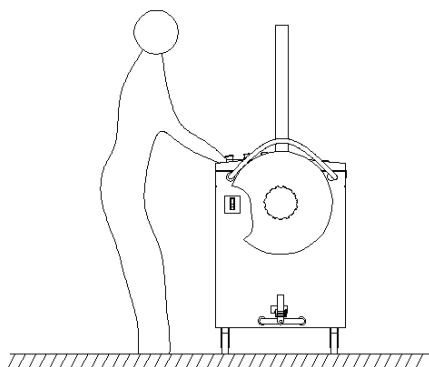

Fig1-1

Safety cautions to operate machine

- ①. Please confirm the power supply for the machine. Don't plug wrong power supply. This machine adopts 3-phase 4-wire and flex is grounding zero line as electric leakage guard.
- ②. On operation, don't pass head and hand through the course of the strap.
- ③. Don't directly touch the heating sheet by hand.
- ④. Don't flushing the machine by water. If the workplace is humid, the operating staff should not operate on barefoot.
- ⑤. Don't change or increase and decrease the parts freely.
- ⑥. If the machine isn't used, please roll back the strap in the strap storage into the strap spool to avoid deformation for next use.
- ⑦. Don't stick oil to the roller wheel surface of transport strap.
- ⑧. While the machine isn't used, please pull out the power plug.
- ⑨. Parts and components required charging oil and listed in the instruction should frequently be lubricated by oil.

1.7 Machine radialization safety

1.7.1 Noise:≤75DB

2 Machine specification, installation and debug

2.1 Specification

2.1.1 Model No. of machine: MH-102A

2.1.2 N.W: 280kg

2.1.3 G.W: 320kg

2.1.4 Volume: 1.5 m³

2.1.5 Manufacturing date: refer to acceptance certificate

2.1.6 Manufacturing address: Hangzhou, China

2.2 Disassembly, installation, transportation and storage conditions

2.2.1 Machine structure and main parts illustration (Fig 2-1)

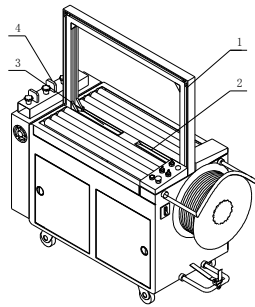

- 1.Aluminum alloy frame
- 2.Right strap path
- 3.Left strap path
- 4.Photoelectricity switch

Fig 2-1

2.2.2 Disassembly

On delivery, the bailing press is divided into the following parts: cabinet, aluminum alloy frame, left strap path and right strap path. Cabinet is packed with wooden box. Aluminum alloy frame, left strap path and right strap path packed with foam and put into wooden box for packaging.

2.2.3 Installation

① Installation of aluminum alloy frame

Shown as Fig 2-2, put aluminum alloy frame in the slot frame shown as Fig 2-3. Fix M8X20 hexagonal socket screw onto the slot frame. See as Fig2-4.

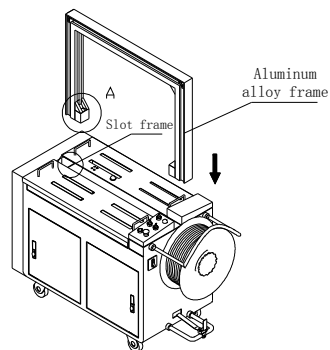

Fig 2-2

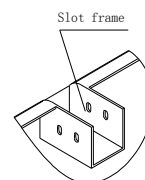

Fig2-3

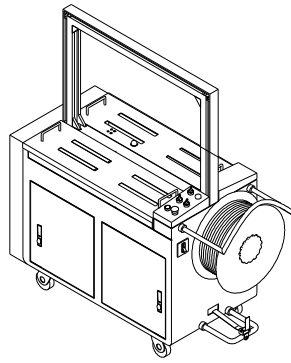

Fig2-4

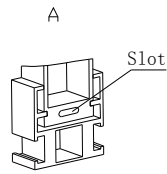

Fig2-5

② Install left strap path

Insert one head of left strap path shown as the finger into aluminum alloy frame slot shown as Fig2-5. The other head fixed onto the support plate of the cassette mechanism of bailing press by M5X12 hexagonal socket screw. Shown as Fig2-9. Assure that the gap between middle left strap path and T guide plate is $H=2\text{mm}$.

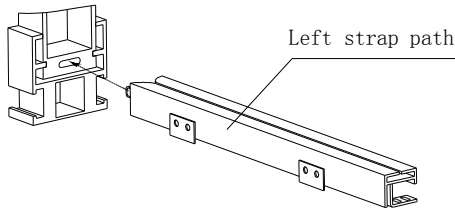

Fig 2-6

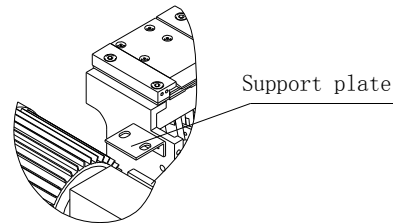

Fig2-7

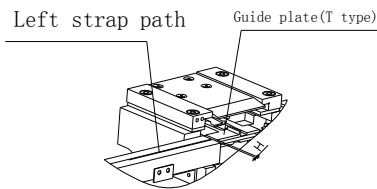

Fig 2-8

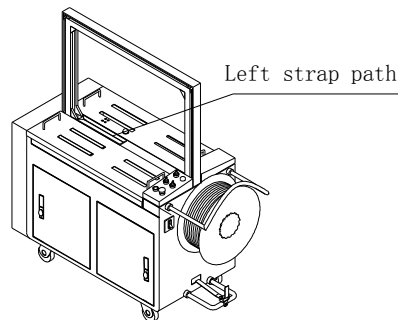

Fig 2-9

③ Install right strap path

Insert one head of right strap path into aluminum alloy slot in the arrow direction. Shown as Fig2-11, tighten it by screw. Shown as Fig2-11.

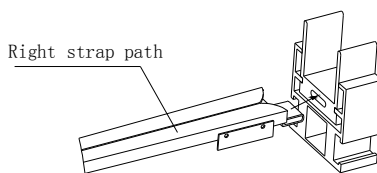

Fig 2-10

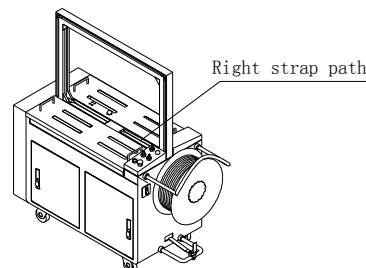

Fig 2-11

2.2.4 Transportation

Transport by liftruck (see as Fig2-12)

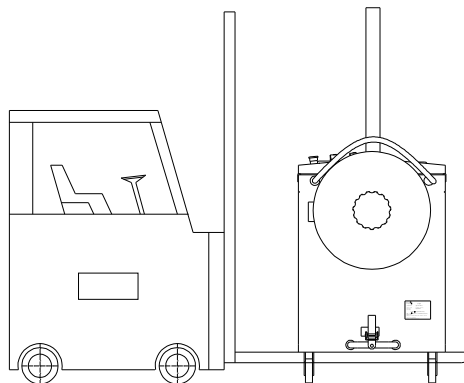

Fig 2-12

2.2.5 Operation environment conditions

It should be far from smoke, dry and ventilate, no erosion of corrodent. Humidity \leq 98%。

Normal environment temperature should within 0-40℃. No special requirements for electromagnetic radiation.

2.3 Debug

2.3.1 Check before operation

- ①. Check whether the fastening pieces are loosened
- ② Charge liquid lubricating oil into decelerator and observe whether the oil path is smooth (See Fig2-13)

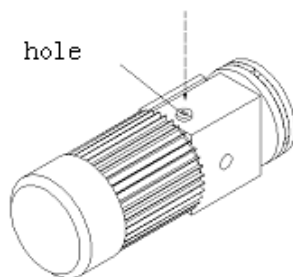

Fig2-13

- ③. Check whether the motor and electric equipment are dry and with good insulation
- ④ Check whether the external power is fit for the power supply of the machine

2.3.2 Empty operation

After switching on the power, press “CONTINUOUS” button. Continually empty operate and check whether the position of proximity switch is right.

- ① When the two proximity switches induce strap-feeding sonde shown as Fig 2-14, main motor starts and the machines starts feeding strap.

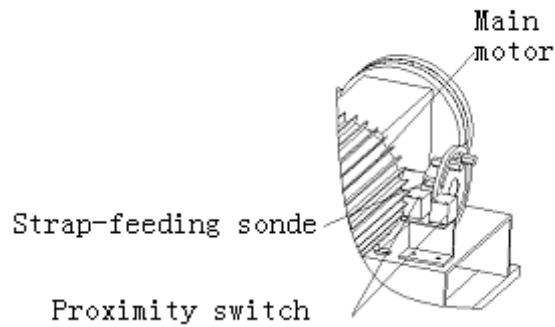

Fig 2-14

- ② When the two proximity switches induce strap-withdrawing sonde shown as Fig 2-15, main motor stops running , strap-withdrawing motor starts, the machine starts withdrawing strap.

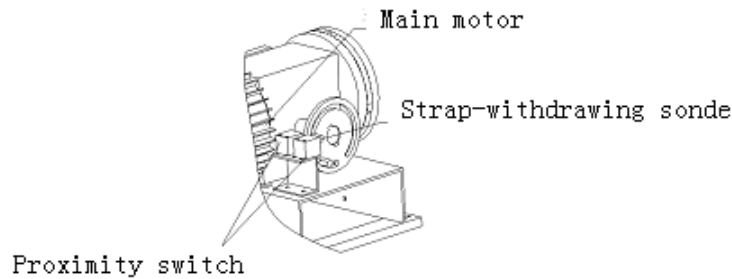

Fig 2-15

- ③ When the two proximity switches induce strap-feeding sonde shown as Fig 2-16. Main motor stops running.

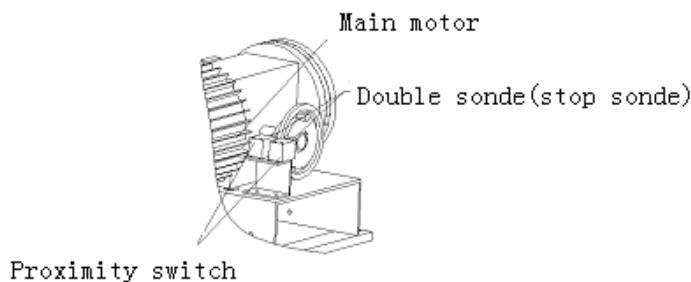

Fig 2-16

3 Principle of operation and flow

3.1 Principle of machine operation

The bailing object is basically located in the middle of the machine. First the right top body ascends, impacting the front end of the clamping strap. Tightening the strap and strapping the object. Subsequently left top body ascends and impacts the proper place of lower layer strap. Heating slice stretches into the middle of two straps. Middle top knife ascends, cut off strap, finally feeding next bundle strap to the position and finish one cycle.

3.2 Work flow

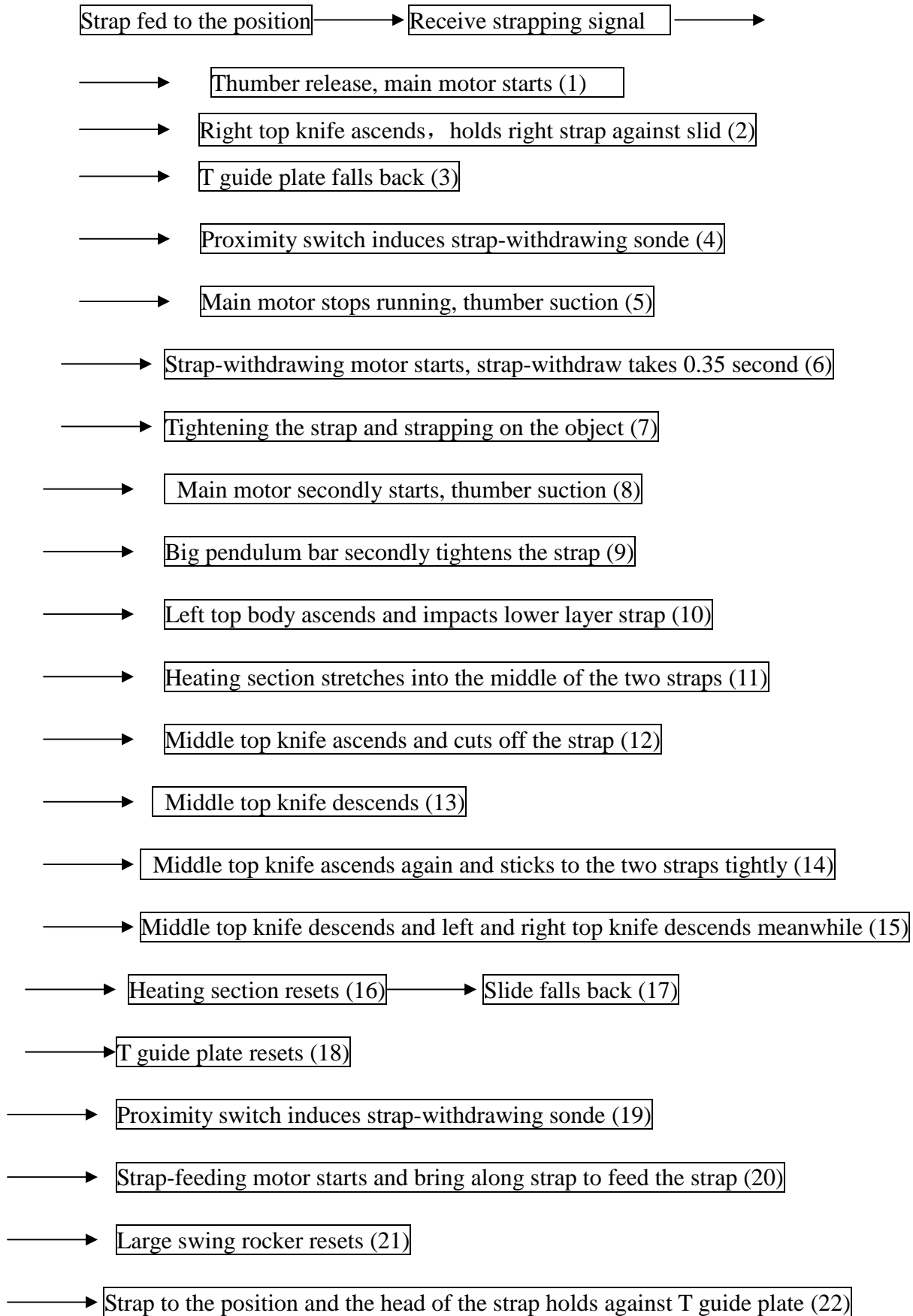

- Proximity switch induces double sonde (23)
- Main motor stops running and brake suction (24)
- Finish one operation cycle

4 Machine operation

4.1 Functions of control panel (see as Fig 4-1)

① Power light

If power light is on, it shows that the switch doesn't close

② Power switch

③ Strap-feeding and withdrawing switch

④ Option switch of work mode

When the switch of press button "PACKING DESIGN" points to "CONTINUOUS", the machine continually straps every a period of time (adjustable); When pointing to "AUTOMATIC" and pressing ball switch, the machine automatically straps. While on "HAND-RUNNING", press 6 "PACK" button and realize strapping.

⑤ Emergency stop button

No matter what situation the machine is under. Once requiring the machine to stop running immediately, just pressing this button. If requiring restart, turn an angle in arrow direction on the switch to restore the original shape.

⑥ Strap button

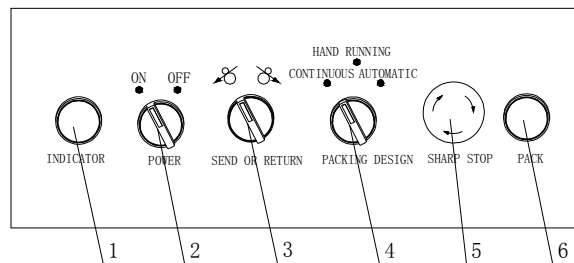
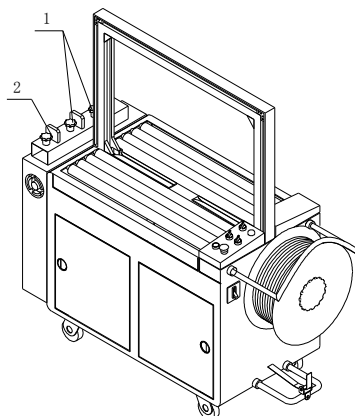

Fig4-1

4.2 Function of photoelectricity switch

See as Fig 4-2.



1. Photoelectricity switch: Control quantity of strapping and distance of strap.

2. Photoelectricity switch: Control the start of roller.

★ Remark: Don't change the order of three photoelectricity switch.

4.3 Method of feeding strap

① Load the bailing strap on the strap stool. Load the bailing strap according to the course shown as Fig 4-2. After the head enters the jaw to insert the strap, turn the knob in the pre-strap-feeding mechanism in clockwise direction. Make the two tape wheels far from a distance to pass strap head through two tape wheels and enter strap storehouse. Pull the strap head by hand and then turn the emergency stop button on the control panel and the bailing strap will automatically be full of strap storehouse.

② After the strap head is pulled out from the upper opening of the strap storehouse, inserted into the strain swing rocker shown as Fig 4-3 and passes through two tape wheels. At this time turn button 3 on the control panel to the position of "SEND" and the bailing strap will be full of strap path. Thus strap-transporting is finished and preparation of bailing is ready.

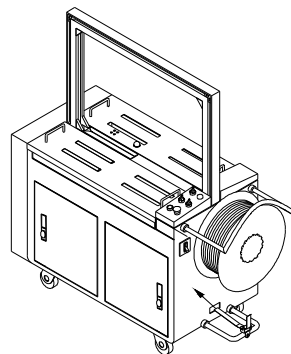

Fig4-2

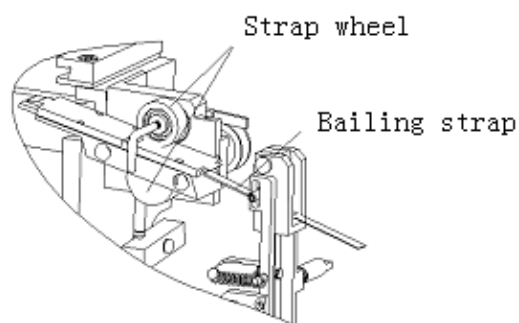

Fig4-3

4.4 Operation steps

- a. Put through air switch shown as Fig4-1 and power light is on.
- b. Put through power switch 2. If the strap is not full at this time, the machine will automatically feed the bailing strap into strap storehouse until the strap storehouse is full.
- c. If there is not bailing strap in the strap path or the bailing strap does not reach the position, turn strap-feeding and withdrawing button3 to the position of "SEND"

to make it feed strap.

d. 30 seconds after switching on the power and the heating section reaches strapping temperature, it's possible to do strapping.

e. Select strapping mode:

In Fig4 the button of "PACKING DESIGN" is strapping mode button, including three modes: "CONTINUOUS", "MANUAL", "AUTOMATIC".

① CONTINUOUS: Don't operate any switch and the machine and ceaselessly straps according to adjusted interval, applied to large volume flow production.

② MANUAL: Strap once on pressing strapping button 5 once, applied to the occasion of relatively slow speed or scattered strapping.

● AUTOMATIC: When the switch is on gear, the roller send the object automatically, but not strapping.

f. No matter what situation the machine is under. Once requiring the machine to stop running immediately, just pressing 5 button. If requiring restart, turn an angle in arrow direction on the switch to restore the original shape.

4.3 Daily maintenance

Frequently making proper maintenance to the bailing press is not only to prolong the life of the machine but to avoid the trouble so as to advance production efficiency.

4.3.1 Charging oil to lubricate

The sealing speed of this machine is very fast. For the large work volume, each machine has to operate 16 hours per day. Therefore its machine part should often be under better lubrication condition. The following position should charge oil once every week and the oil No. is N68. Those parts not listed into this manual also should charge butter at irregular intervals according to actual requirements.

★ Oil-charging position

Before charging oil, please firstly clean the position to be charged and wipe it by cloth such as towel.

a. Slide board and guide plate (Fig4-4)

Take off the guide plate and smear the lubricating oil on four areas playing guide role, then put it into guide rail.

b. Operation surface and roller of each cam

c. Guide rail of heating body (Fig4-5)

d. Strap-clipping block (Fig4-6)

Smear oil on both sides and inside hole of the strap-clipping block

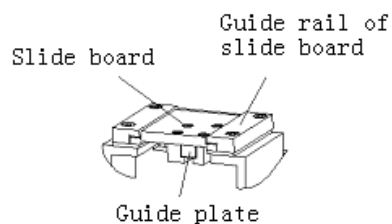

Fig4-4

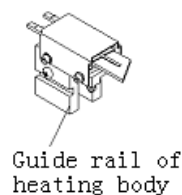

Fig4-5

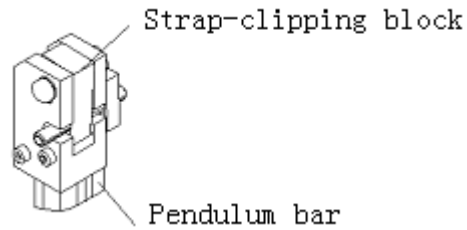

Fig4-6

4.3.2 Decelerator adds oil quantitatively

Oil-charging volume is appropriate when the oil surface is located at the center of the oil scale. If more, it will affect the normal operation of the machine.

4.3.3 Regularly examine the fastness of proximity switch and its sonde

If proximity switch and its sonde are not fixed tightly and change the relative position, it will cause the change of stop position of the bailing press and the time to feed and withdraw the strap. The machine can't operate normally due to disaccord and affects the bailing quality.

4.4 Delivery setting

1mm bailing strap passes through two strap wheels shown as the Figure and the gap between crown bar and pry bar is 0.3mm (See Fig4-7)

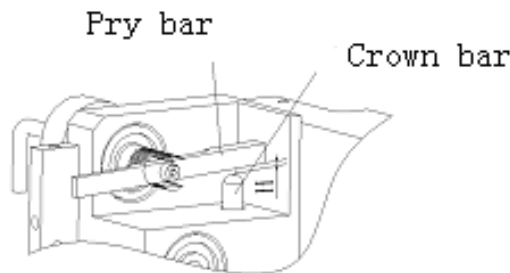

Fig4-7

The gap H between main motor and the brake of main motor is adjusted to 0.2mm-0.3mm (See Fig4-8)

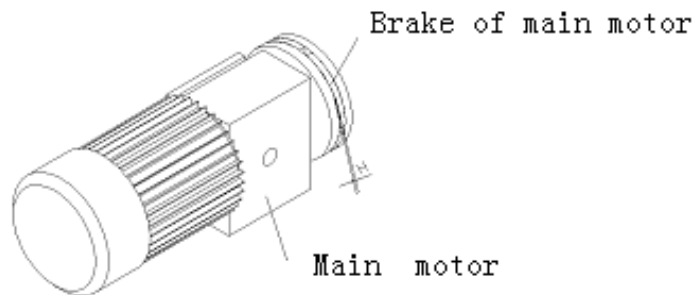

Fig4-8

4.5 Adjustable position

This position is located at front right door. Adjustment of tightness force shown as Fig4-9. Generally knob to adjust strapping force is seized and can't turn. On adjusting strapping force, first forcibly push the knob to the bottom. At this time you can freely turn the knob. The strapping force is decreased while turning knob in clockwise direction and increased in anticlockwise direction. In general, on delivery the position of swing link bearing and orientation tray shown as the left Figure. Generally it is not necessary to adjust their corresponding position.

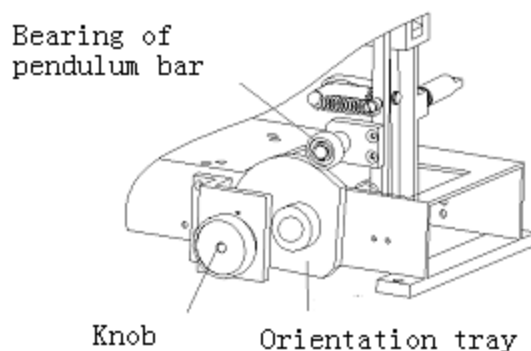

Fig4-9

If the temperature in work field is with large variation, adjust the temperature of heating section by temperature-control device: the temperature in 2 gear is lowest and 10 gear highest (See Fig4-10).

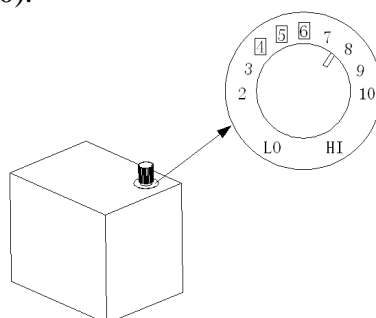

Fig4-10

5 Maintenance and Troubleshooting

5.1 Safety warning on maintenance

- ① Assure to cut off chief power supply
- ② The repairing staff should not operate on barefoot

5.2 Regularly maintenance and cleaning

- ① Regularly check whether the screws of each part are loosened
- ② Regularly lubricate the important parts of the machine by oil
- ③ Regularly clean up the strap scrap generated during bailing in the cassette mechanism to prevent from affecting bailing quality
- ④ Maintain the machine surface clean

5.3 Frequent trouble and troubleshooting

5.3.1 Frequent trouble under normal usage situation

5.3.1.1 Adhesive effect of the strap is not so good: a. Temperature of heating section is too high or too low

b. Deformation of heating section

If heating section is deformed, it can't be inserted into the middle of double-deck strap and upper and lower double-deck strap can't bind (See Fig5-1)

c. Because strap is not fed to the position, it causes bad adhesion: because the strap head can't reach presetting position, adhesion is bad

d. Strap head is split: The reason is that the strapping force is too large. Properly adjust strapping force small (See Fig4-9)

e. The pressure of middle top body is not enough big: The compression spring in middle top body is cracked and decreases the top pressure

f. Used bailing strap is too thin so that top pressure is not enough. If using this bailing strap, spacer less than 0.5mm should be added under middle top knife to thicken it (See Fig5-2)

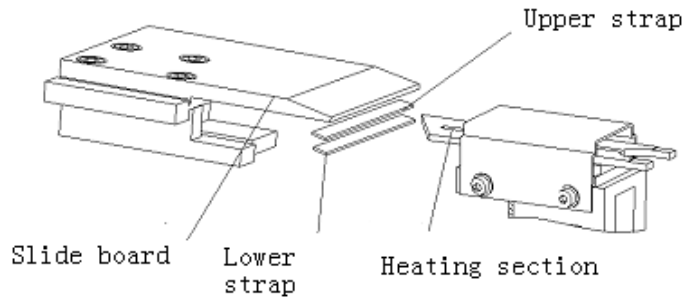

Fig5-1

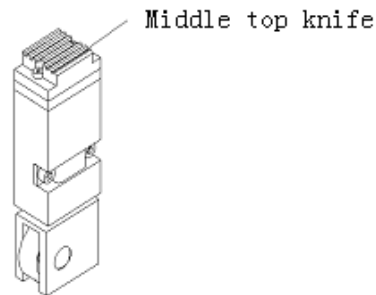

Fig5-2

5.3.1.2 Strap is not fed to the position

a. Tensioning force of pry bar is too large or too small: properly adjust the pressure of roller wheel (see Fig5-3)

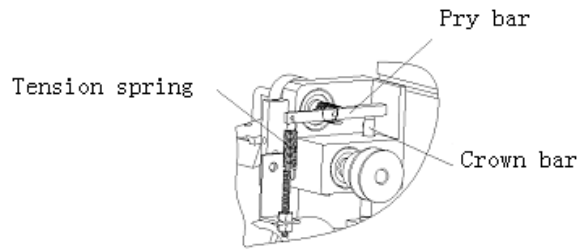

Fig5-3

- b. The position of crown bar is too high: If not on strap-withdrawing, the gap between crown bar and pry bar should be 0.3mm (See Fig4-7).

If due to improper adjustment, crown bar always holds against the pry bar and the holding force is very large, it will cause the phenomenon that strap is not fed to the position.

- c. Strap storage volume in strap storehouse is few: If there is not enough strap, it will cause the case that strap is not fed to the position.

Reasons: (1) improper adjustment of pre-strap-feeding mechanism. Adjust strap storage volume properly

(2) Trouble of pre-strap-feeding mechanism or strap storehouse problem causes small strap storage volume. Find out the trouble and solve it.

- d. Strap head is split: If strap head is split, it will not run smoothly in the strap path and lead to the situation that strap is not fed to the position. The reason is that the strapping force is too large. Therefore properly adjusting strapping force will eliminate this situation (See Fig4-9).

- e. Strap-pressing plate is too low (See Fig5-4): Strap-pressing plate is set for convenient feeding strap. But if it is adjusted too low with a small gap to swing link bottom and affects freely feeding and withdrawing of the strap, it will cause this situation. At this time properly raise the strap-pressing plate.

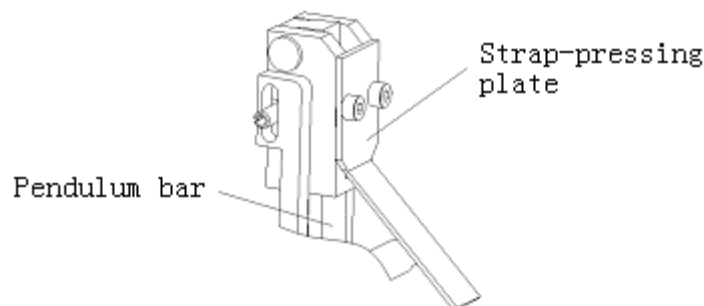

Fig5-4

- f. Middle top knife is not fixed firmly: Middle top knife on the middle body is not fixed firmly and generates displacement, closely leaning against another knife board. Reset can't reach the position and causes T guide plate out of the position. Strap head jumps no direction due to no guide of the guide plate and leads to the situation

that strap is not fed to the position. Therefore after adjusting or disassembly middle top knife should fix firmly (See Fig5-2).

- g. Quality problem of bailing strap: Width and thickness of bailing strap is too big or too small and bending too much. All will cause this situation.

Judging method: Through manual feeding strap, if it can't reach the position, the quality of the strap is not fit for the requirements of the machine; If it's smooth, check other troubles.

- h. Can't strap firmly (See Fig4-6 and Fig4-9):

- ① Strapping adjustment device is at the loose position
- ② Strap-clipping block wears seriously
- ③ Teeth groove in the strap-clipping block is full of strap scraps
- ④ Tension spring of pulling bar is cracked
- ⑤ Push bearing of pendulum bar is cracked
- ⑥ Torsion spring is cracked

- i. Pull big round:
- ① Strap-withdrawing time is not enough
 - ② The force of strap-withdrawing is too big or too small. Check the gap between strap-withdrawing crown bar and pry bar (See Fig 4-7)
 - ③ Resistance of frame is too large
 - ④ Motor belt is too loose

- 5.3.1.3 Power light is not on: ① Whether power plug and wiring socket contacts well
② Whether air switch is on OPEN

- 5.3.1.4 Can't bail: Whether emergency stop button is pressed

5.4 Components items repaired or changed by operator

No.	Change component name	Remark
1	Heating section combination	
2	Strap-clipping block	
3	Various fuse	
4	Back and forth cover plate	
5	Strap-shielding plate	
6	Belt of main motor	Japan Mitsubishi
7	Belt of strap-feeding and withdrawing motor	Switzerland Habasit
8	Belt of pre-strap-feeding motor	Switzerland Habasit
9	Pre-strap-feeding motor	Taiwan Dongli or Chengbang
10	Brake strap	Switzerland HABASIT
11	Torsion spring on left and right strap path	

5.5 Components items repaired or changed by professional staff

No.	Change component name	Remark
1	Compression spring of middle knife	
2	Tension spring of middle knife	
3	Tension spring of middle knife	
4	Middle relay	Japan OMRON
5	Tension spring of large swing link	
6	Tension spring of brake	

6 Main parts and components illustration and parts list

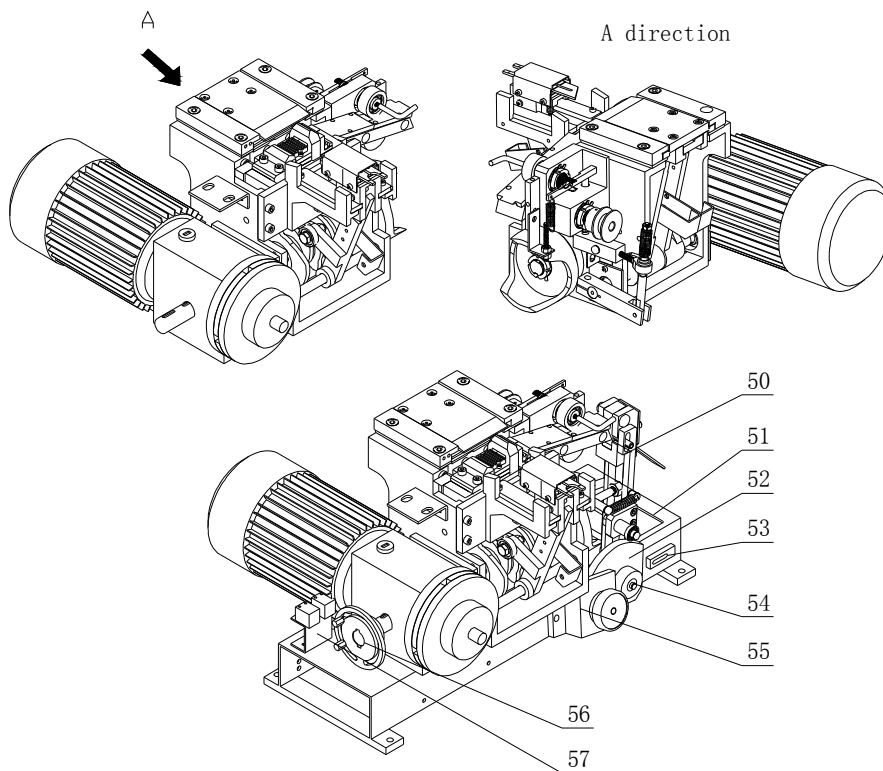
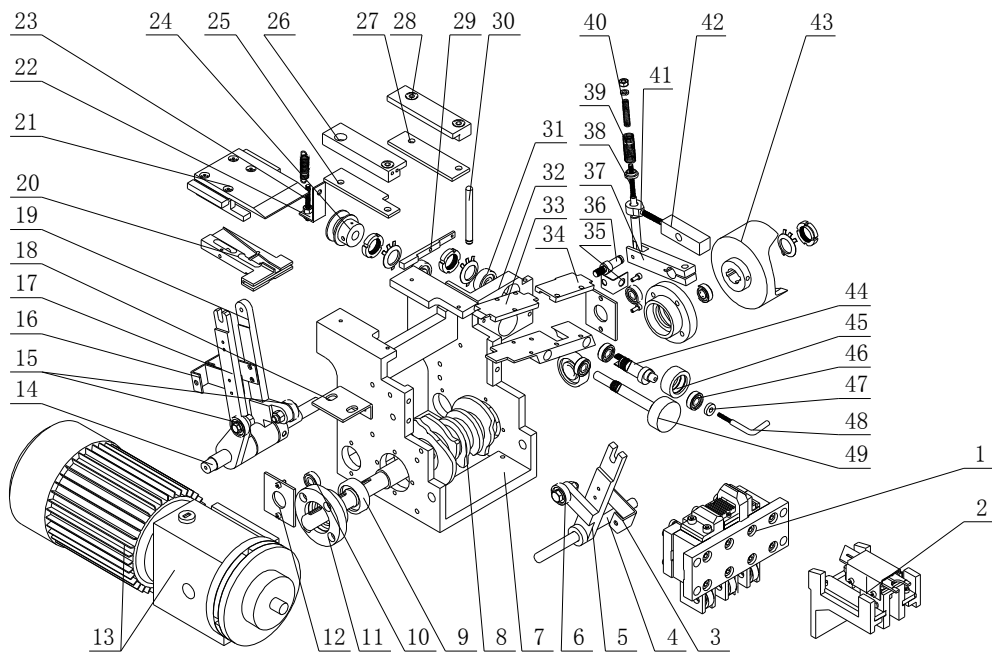

Sketch map of cassette mechanism

Parts list

No.	Name	Code No.	Quantity	Remark
1	Top body combination		1	See the Figure
2	Heating body combination		1	See the Figure
3	L Plank	01-221	1	
4	Spindle	01-131	1	
5	Heating bracket		1	
6	Bearing	80100	1	Import
7	Large bracket	01-1	1	
8	Parts of principal shaft		1	See the Figure
9	Bearing	80104	2	
10	Bearing	80102	2	
11	Bearing pedestal	01-14	2	
12	Baffle plate	01-18	2	
13	Motor and decelerator		1	
14	Spindle	01-17	1	
15	Bearing	80100	2	
16	L Plank	01-221	2	
17	Pendulum bar of guide plate	01-224	1	
18	Support plate	01-67	1	
19	Pendulum bar of slide plate	01-217	1	
20	T guide plate	01-226	1	
21	Slide plate combination		1	See the Figure
22	Bent plate	01-33	1	
23	Hexagonal screw		1	
24	Belt wheel	01-39	1	
25	Left guide plate	01-24	1	
26	Left guide rail	01-22	1	
27	Right guide plate	01-25	1	
28	Right guide rail	01-23	1	
29	Pry bar	01-32	1	
30	Crown bar	01-51	1	
31	Bearing	50102	4	
32	Roller wheel rack	01-1-2	1	
33	Front lid	01-56	1	
34	Back lid	01-57	1	
35	Bent plate	01-40	1	
36	Spindle	01-50	1	

37	Clamping arm	01-200	1	
38	Drag bar	01-197	1	
39	Spring		1	
40	Spring		1	
41	Knuckle bearing		1	
42	Pendulum block	01-196	1	
43	Edge cam	01-11	1	
44	Eccentric shaft	01-35	1	
45	Roller wheel	01-36	1	
46	Bearing	80100	1	
47	Clamping ring	01-38	1	
48	Wrench	01-42	1	
49	Roller wheel spindle	01-37	1	
50	Strapping swing link		1	See the Figure
51	Channel steel		1	
52	Orientation tray	01-68	1	
53	Limit board	01-69	1	
54	Spindle	01-45	1	
55	Adjustment device of strapping force		1	See the Figure
56	Sonde bracket		1	
57	Switch bracket	01-65	1	

Slide combination

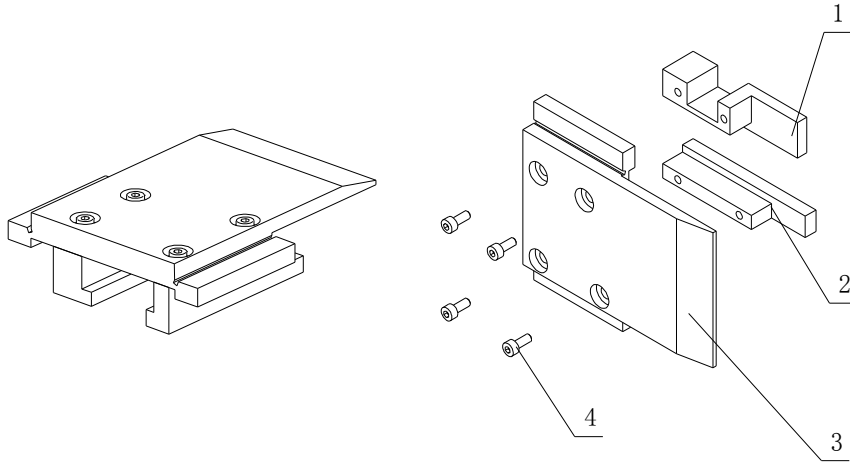

No.	Name	Code No.	Quantity	Remark
1	Right rail of guide plate	01-27	1	
2	Left rail of guide plate	01-26	1	
3	Slide plate	01-20	1	

Top body combination

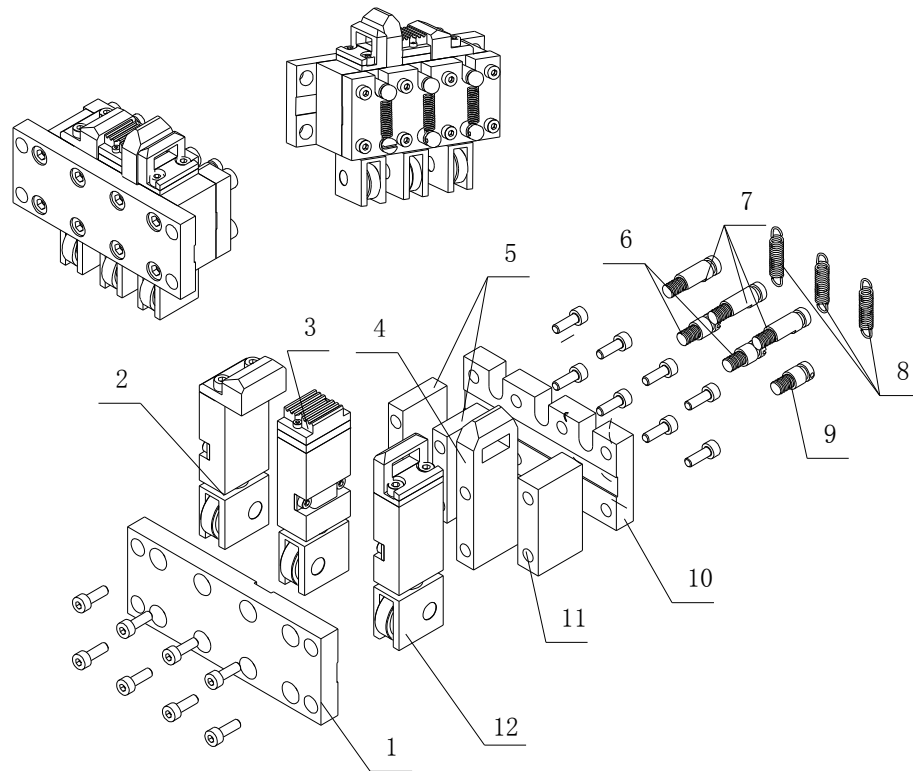

No.	Name	Code No.	Quantity	Remark
1	Front plate	01-90	1	
2	Left top knife combination		1	See the Figure
3	Middle top knife combination		1	See the Figure
4	Right partition board	01-93	1	
5	Left partition board	01-92	2	
6	Post	01-95	2	
7	Post	01-109	3	
8	Tension spring	01-97	3	
9	Post	01-96	1	
10	Back plate	01-91	1	
11	Baffle plate	01-94	1	
12	Right top knife combination		1	See the Figure

Left top knife combination

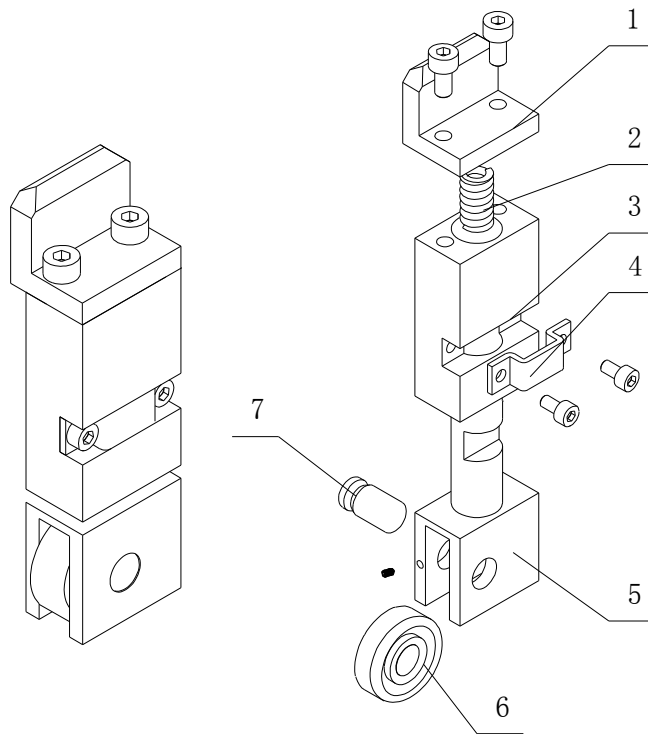

No.	Name	Code No.	Quantity	Remark
1	Left jackcatch	01-112	1	
2	Compression spring	01-104	1	
3	Cavity	01-101	1	
4	Limit stop	01-105	1	
5	Spring pedestal	01-100	1	
6	Bearing	80100	1	
7	Small spindle	01-106	1	

Middle top knife combination

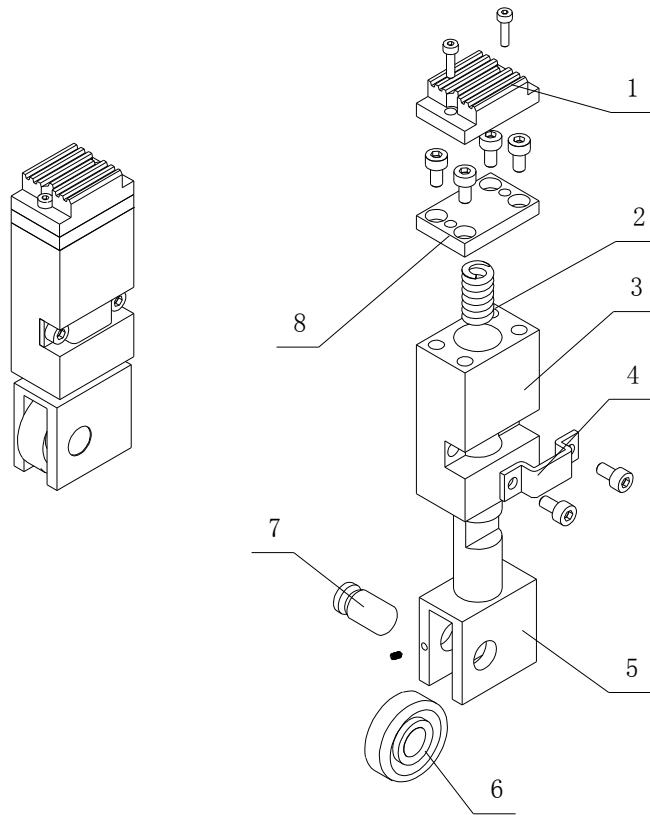

No.	Name	Code No.	Quantity	Remark
1	Top body	01-114	1	
2	Compression spring	01-104	1	
3	Cavity	01-102	1	
4	Limit stop	01-105	1	
5	Spring pedestal	01-100	1	
6	Bearing	80100	1	
7	Small spindle	01-106	1	
8	Seat board	01-113	1	

Right top knife combination

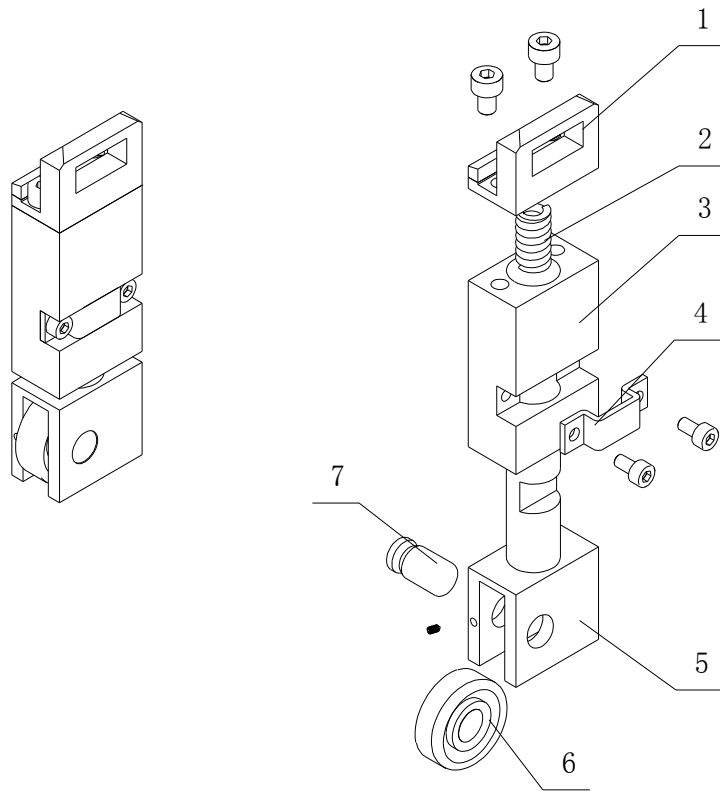

No.	Name	Code No.	Quantity	Remark
1	Right jackcatch	01-115	1	
2	Compression spring	01-104	1	
3	Cavity	01-101	1	
4	Limit stop	01-105	1	
5	Spring pedestal	01-100	1	
6	Bearing	80100	1	
7	Small spindle	01-106	1	

Spindle components

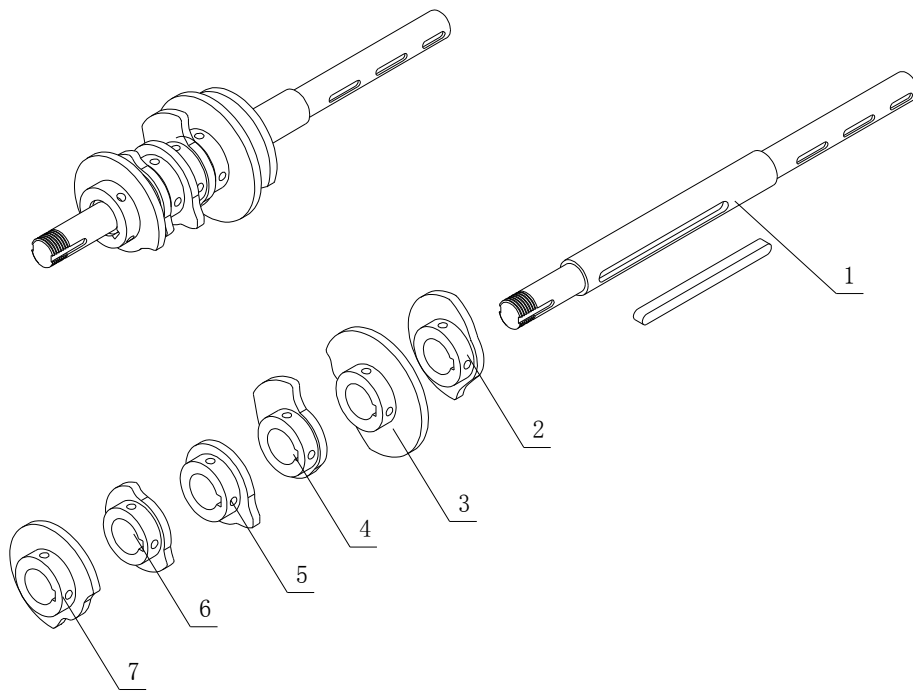

No.	Name	Code No.	Quantity	Remark
1	Main spindle	01-27	1	
2	Cam	01-5	1	
3	Cam	01-6	1	
4	Cam	01-7	1	
5	Cam	01-8	1	
6	Cam	01-9	1	
7	Cam	01-10	1	

Heating body combination

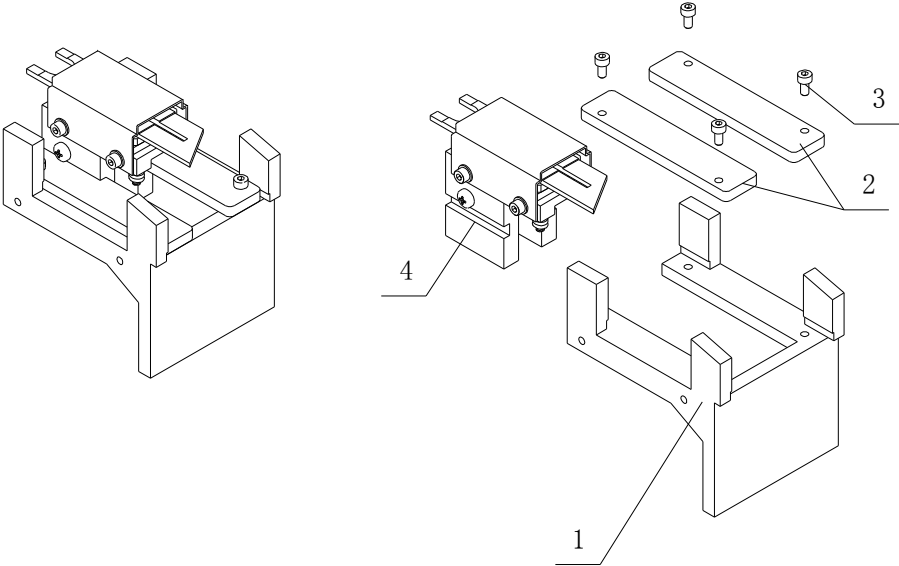

No.	Name	Code No.	Quantity	Remark
1	Bracket	01-130	1	
2	Guide plate	01-132	2	
3	Combination of heating section and slide plate		1	See the figure

Combination of heating section and slide plate

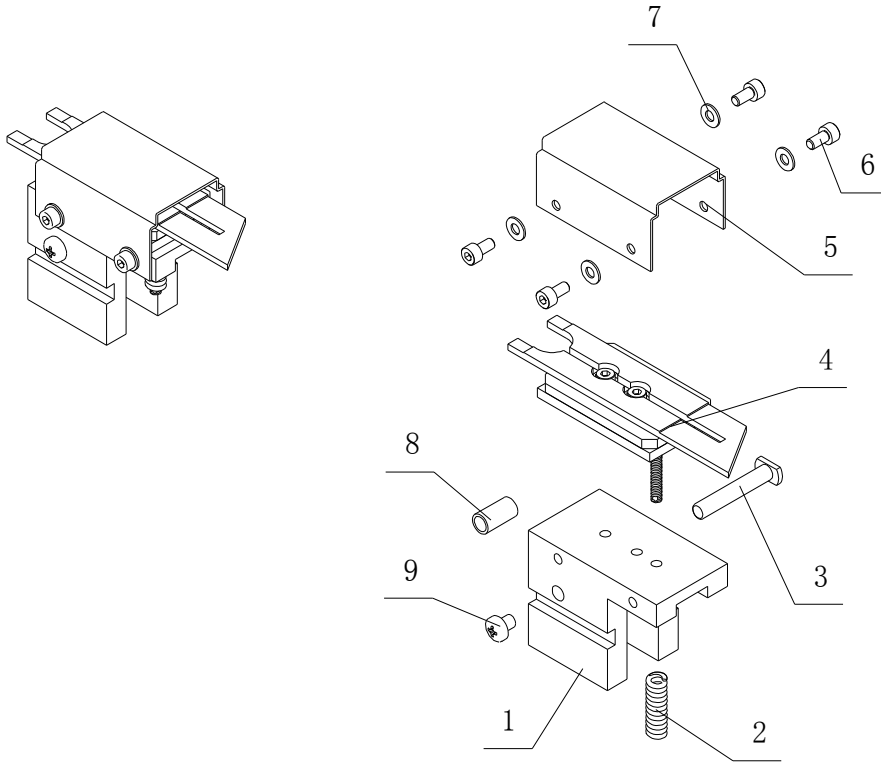

No.	Name	Code No.	Quantity	Remark
1	Slide	01-137	1	
2	Compression spring	01-140	1	
3	Spindle	01-138	1	
4	Heating section combination		1	See the figure
5	Cover	01-142	1	
6	Axle sleeve	01-139	1	

Heating section combination

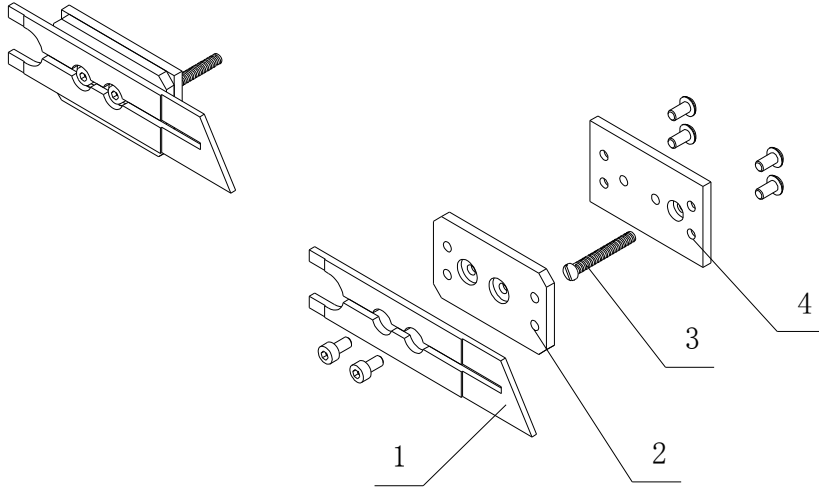

No.	Name	Code No.	Quantity	Remark
1	Heating section	01-207	1	
2	Insulation board	01-150	1	
3	Bolt	01-152	1	
4	Base plate	01-151	1	

Adjustment device of strapping force

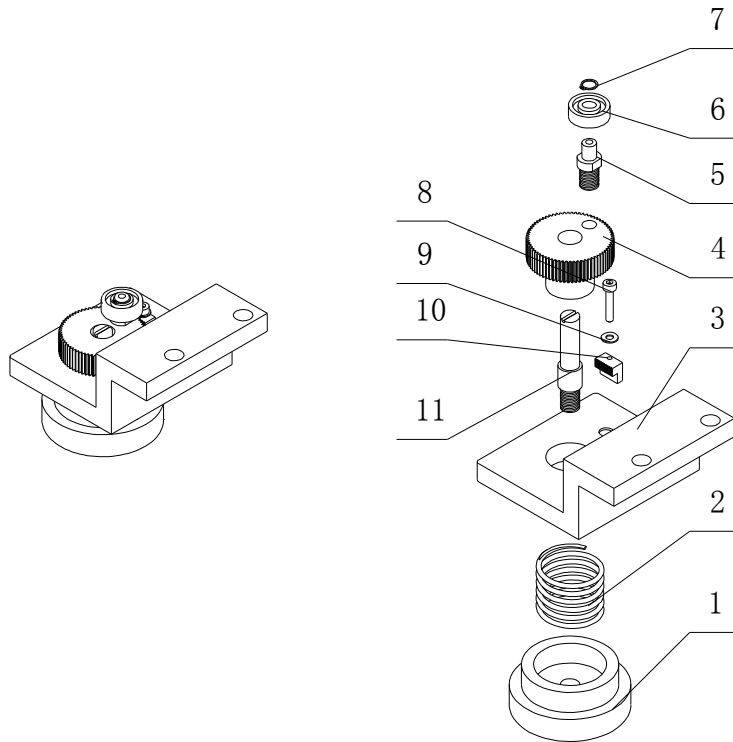

No.	Name	Code No.	Quantity	Remark
1	Knob	01-205	1	
2	Compression spring	01-207	1	
3	Bracket	01-204	1	
4	Gear	01-209	1	
5	Small spindle	01-210	1	
6	Direct rack bar	01-211	1	
7	Spindle	01-206	1	

Strapping pendulum bar

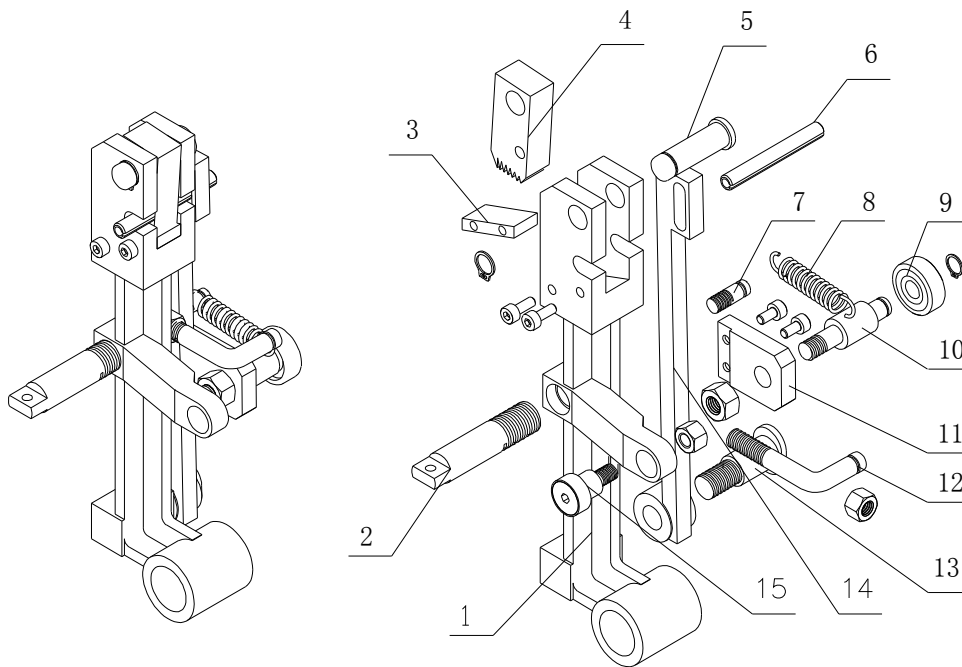

No.	Name	Code No.	Quantity	Remark
1	Pendulum bar	01-160	1	
2	Tension bar	01-169	1	
3	Spacer plate	01-160-1	1	
4	Strap-clipping block	01-165	1	
5	Spindle	01-166	1	
6	Pin	01-164	1	
7	Post	01-174	1	
8	Tension spring	01-162	1	
9	Bearing	80026	1	
10	Small spindle	01-176	1	
11	Pedestal	01-175	1	
12	Bent plate	01-161	1	
13	Pull pole axle	01-168	1	
14	Pull pole	01-177	1	
15	Bearing	CFØ10	1	

Pre-strap-feeding mechanism

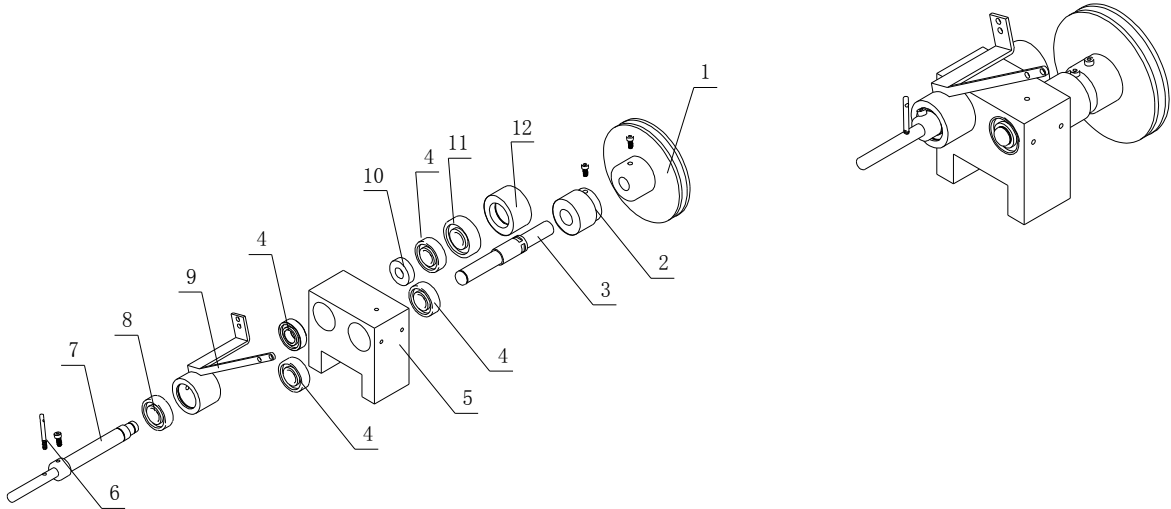

No.	Name	Code No.	Quantity	Remark
1	Belt wheel	00-92	1	
2	Upper strap wheel	00-95	1	
3	Upper axle	00-93	1	
4	Bearing	80102	4	
5	Base	00-83	1	
6	Pendulum bar	00-97	1	
7	Lower axle	00-94	1	
8	Bearing	80100	1	
9	Rocker wheel	00-85	1	
10	Bearing	80101	1	
11	Bearing	80101	1	
12	Lower strap wheel	01-98	1	

Pendulum mechanism

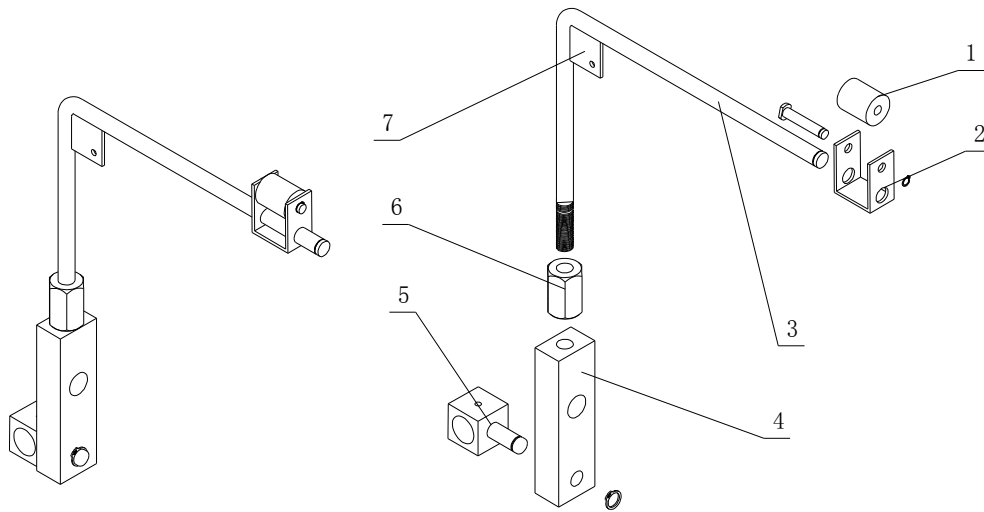

No.	Name	Code No.	Quantity	Remark
1	Roller wheel	00-134	1	
2	Roller wheel rack	00-133	1	
3	Pendulum bar	00-130(1)	1	
4	Swing block	00-127	1	
5	Belt clip	00-128	1	
6	Nut	00-129	1	
7	Hook slice of spring	00-132	1	

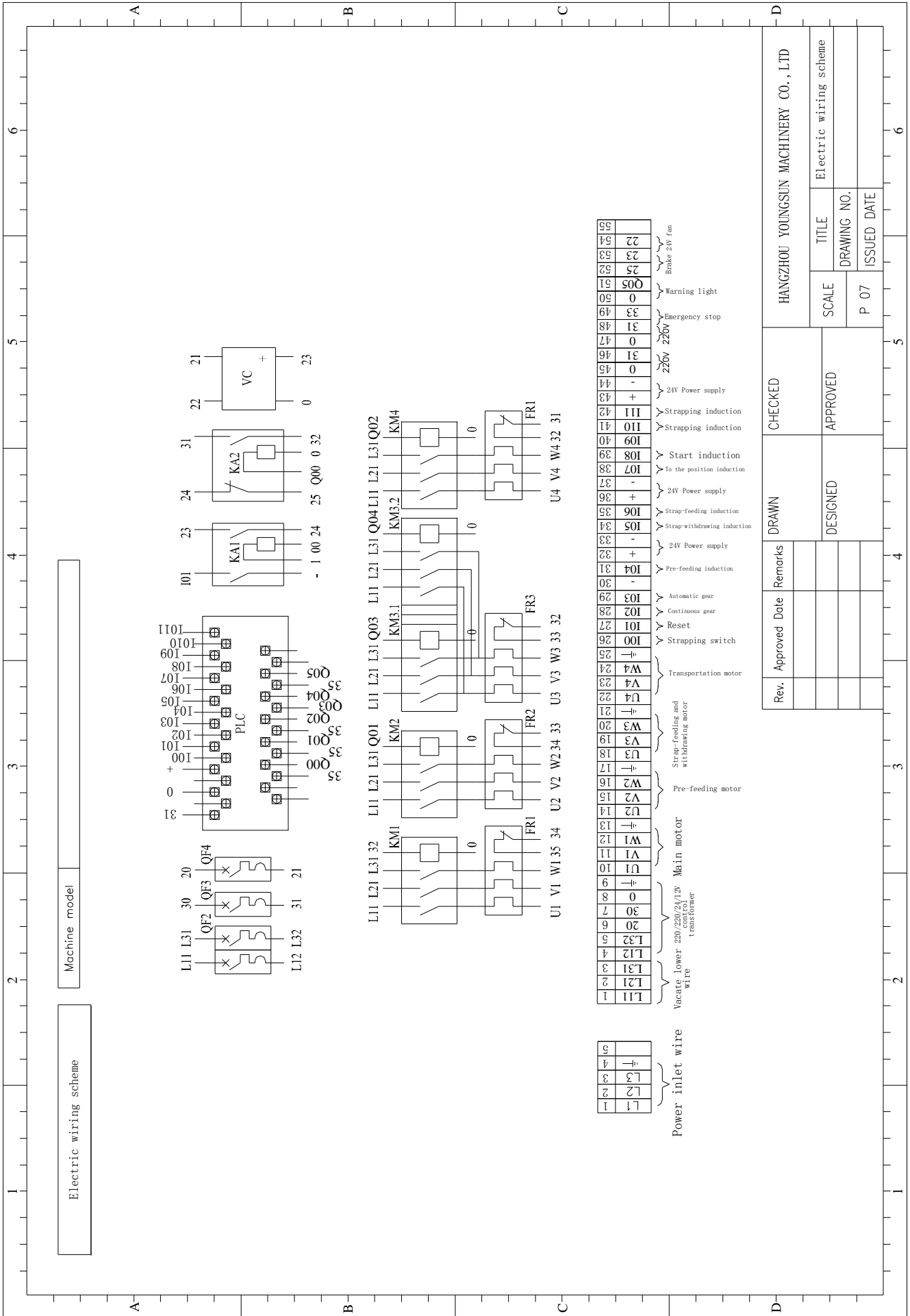

Rev.	Approved Date	Remarks	DRAWN	CHECKED	HANGZHOU YOUNGSUN MACHINERY CO., LTD	
			DESIGNED	APPROVED	SCALE	TITLE
					P 07	Electric wiring scheme
						DRAWING NO.
						ISSUED DATE

Motor start

Machine model		
Main motor	M1	380VAC/ ?3/50HZ/0.37KW
Pre-feed motor	M2	380VAC/ ?3/50HZ/0.25KW
Strap-feeding and withdrawing motor	M3	380VAC/ ?3/50HZ/0.25KW
Transportation motor	M4	380VAC/ ?3/50HZ/0.4KW
Overload relay	FR1-FR3	1-1.6A

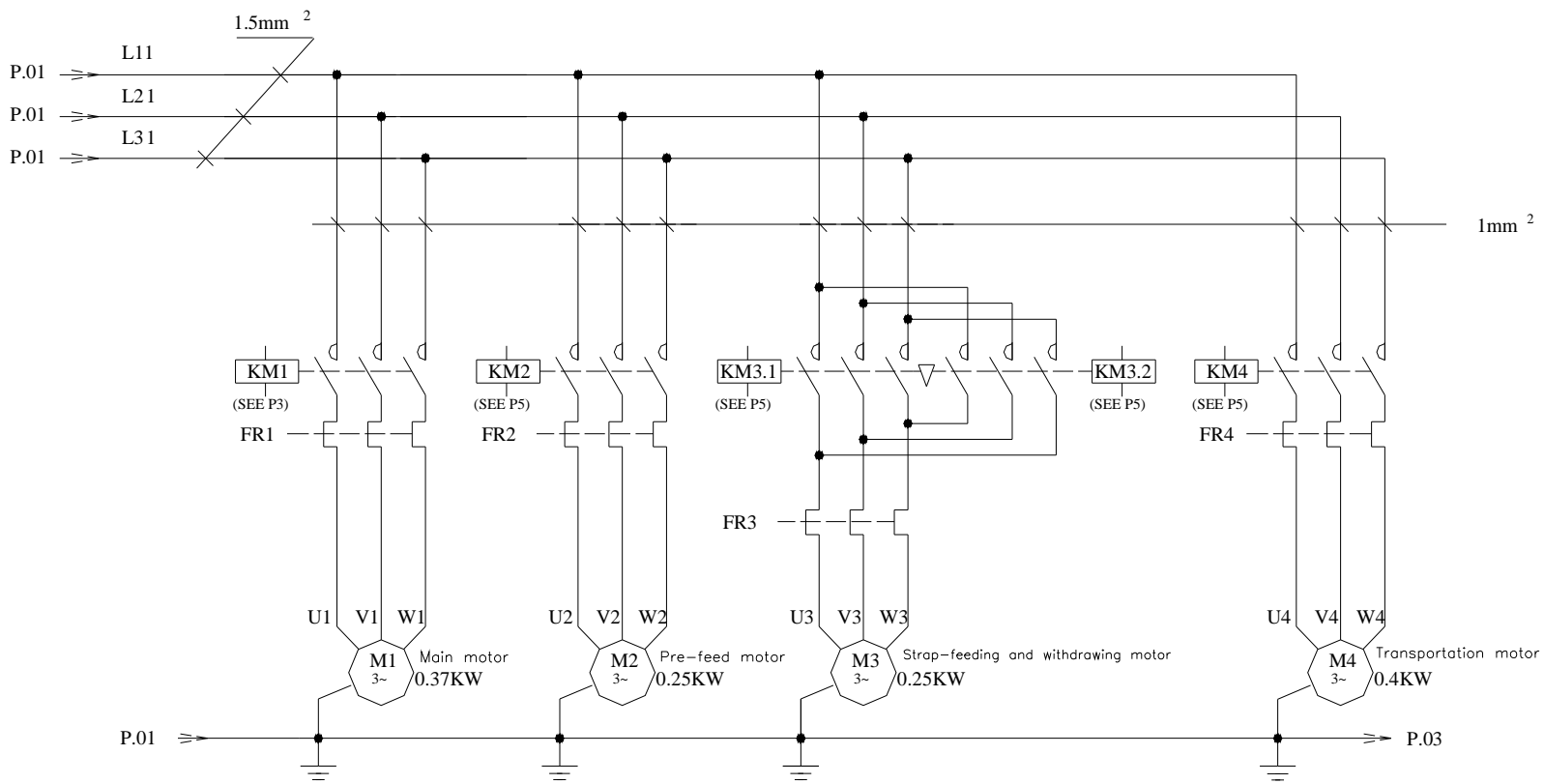

36

Rev.	Approved Date	Remarks	DRAWN	CHECKED	HANGZHOU YOUNGSUN MACHINERY CO., LTD		
			DESIGNED	APPROVED	SCALE	TITLE	Motor start
					P 02	DRAWING NO.	A
						ISSUED DATE	

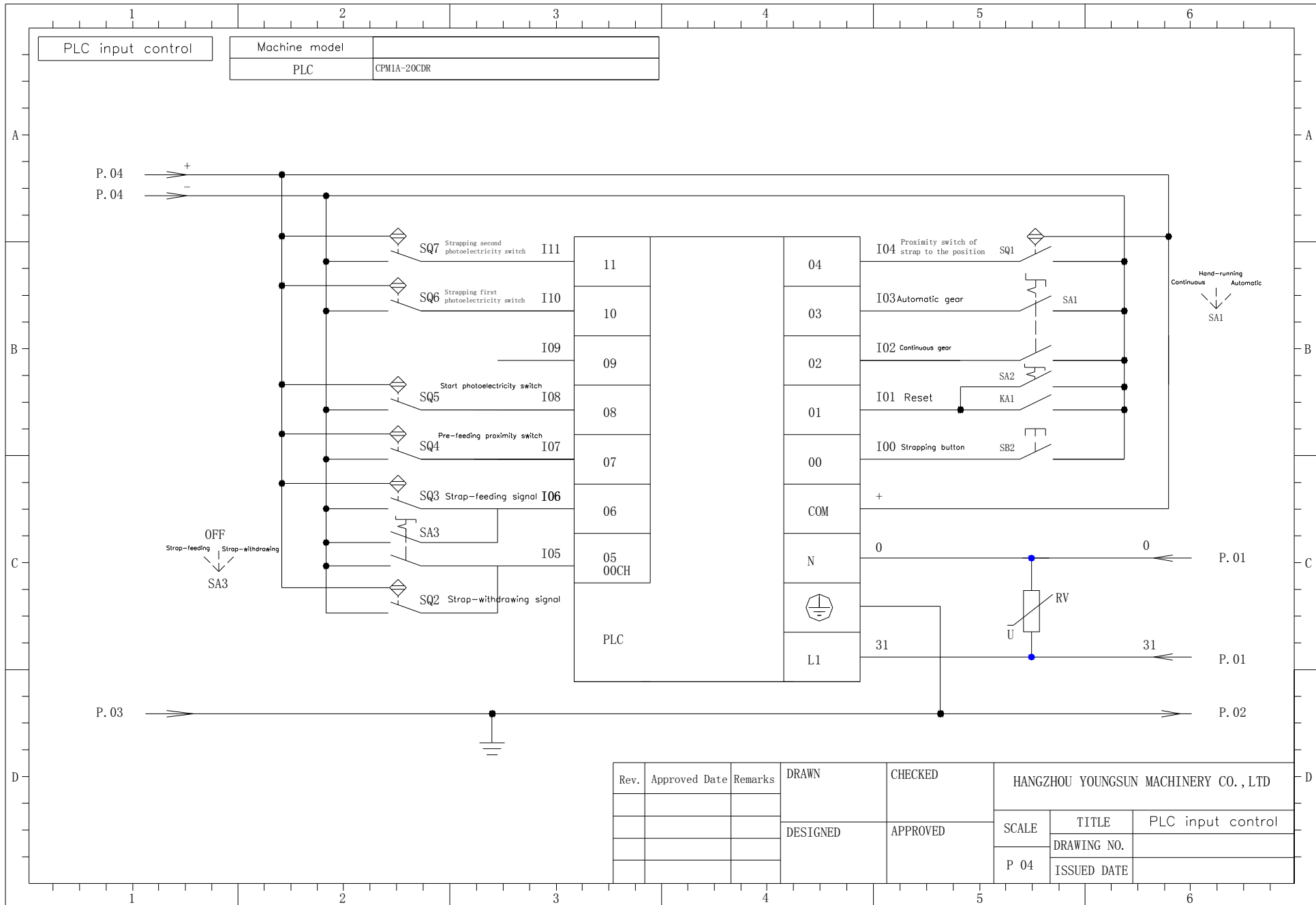

Rev.	Approved Date	Remarks	DRAWN	CHECKED	HANGZHOU YOUNGSUN MACHINERY CO., LTD		
					SCALE	TITLE	PLC input control
			DESIGNED	APPROVED	P 04	DRAWING NO.	
						ISSUED DATE	

Electric component list (MH-102A)

NO.	Code NO.	Name	Brand	Model	Specification	Quantity	Standard	Certification symbol
1	AP	Temperature control board		WK100	0-220VAC	1		CE
2	EH	Heater			200-250°C	1		CE
3	FR1-FR4	Overload relay	TE	LR2-D1306-N	1-1.6A Ui750V	4	IEC60947	CE
4	HA	Warning light	IDEAL	LTA-205	AC220V RED	1		CE
5	HL	Power indicator	TE	XB2-BVM3C	Ui600V	1	IEC60947	CE
6	KA1, KA2	Small relay	OMRON	MY2J	200/220VAC	2	IEC255	CE
7	KM1-KM5	Contactors	TE	LC1-D0610-B5-C	Ith25AUi690	5	IEC60947	CE
8	M1	Main motor	TSINGHUA	YS7124	0.37KW 380V 1.12A	1	IEC34-1	CE
9	M2	Strap-feeding motor	TSINGHUA	YS6334	0.25KW 380V 0.866A	1	IEC34-1	CE
10	M3	Pre-feeding motor	TSINGHUA	YS6334	0.25KW 380V 0.866A	1	IEC34-1	CE
11	M4	Transportation motor	CHENGPANG	CH400-30S	0.4KW 220V 1.24A	1	IEC34-1	UL, CSA
12	M5	Large fan	LUNAN	P/N2123XS	220-240VAC 0.14A	1		UL, CSA
13	M6*2	Small fan	ADDA	AD0624MS-A70GL	DC24V 0.08A	1		UL, CE, CSA
14	PLC	Programmable controller	OMRON	CPM1A-20CDR-A	AC100-240V 30VA	1		UL, CE, CSA
15	QF1	Breaker	mitsubishi	NF50-CS 15AMP	15A	1		CE
16	QF2	Small breaker	CHNT	DZ47-32C5	5A2P230/400V	1	IEC60898	CE
17	QF3-QF4	Small breaker	CHNT	DZ47-32C5	5A1P230/400V	2	IEC60898	CE
18	RV	Varistor		MYG-361K D10		1		
19	SA1	Gear selection switch	TE	XB2-BD21C	Ith10A Ui600V	1	IEC60947	CE
20	SA2	Work selection switch	TE	XB2-BD33C	Ith10A Ui600V	1	IEC60947	CE
21	SA3	Strap-feeding and withdrawing	TE	XB2-BD53C	Ith10A Ui600V	1	IEC60947	CE

		knob switch						
22	SB1	Emergency stop switch	TE	XB2-BS542C	Ith10A Ui600V	1	IEC60947	CE
23	SB2	Strap button switch	TE	XB2-BA31C	Ith10A Ui600V	1	IEC60947	CE
24	SQ1	Proximity switch of strap to the position	FOTEK	PS05N	DC 10-30V NPN	1		CE
25	SQ2	Strap-withdrawing proximity switch	FOTEK	PS05N	DC 10-30V NPN	1		CE
26	SQ3	Strap-feeding proximity switch	FOTEK	PS05N	DC 10-30V NPN	1		CE
27	SQ4	Pre-feeding proximity switch	FOTEK	PS05N	DC 10-30V NPN	1		CE
28	SQ5	Start photoelectricity switch	FOTEK	A3R-1MX	12-240VDC 24-240VAC	1		CE
29	SQ6	Strap photoelectricity switch(I)	FOTEK	A3R-1MX	12-240VDC 24-240VAC	1		CE
30	SQ7	Strap photoelectricity switch(II)	FOTEK	A3R-1MX	12-240VDC 24-240VAC	1		CE
31	TC1	Control transformer	REBB	BK300	T1:380VAC 300VA T2:220VAC 170VA T3:24VAC 100VA T4:12VAC 30VA	1		CE
32	TC2	Heating transformer		220V/1V	100VA	1		CE
33	V	Diode		IN4007		1		
34	VC	Bridge rectifiers	JPEC	QL15A	15A600V	1		
35	XT	Terminal block		JF5-1.5/5		10		
36	YB	Brake	YAN	EFB-015	DC24V 0.7A 1.5KG.M	1		CE
37		Mechanism interlock		LA9D09978C		1		
38		Small relay base		PYF08A		2		